

**Yo-Yo sensing level measurement**  
continuous level indication for bulk solids

**LF**

**Operating instruction**

Index	Page
Safety instructions   Special conditions for ATEX-devices   Use .....	02
Data of manufacturer   Incoming goods inspections and storage   Identification .....	03
Data of measuring devices   Technical data   Electrical data .....	04
Dimensions   Connecting flange .....	05
Sensing weights .....	06
Installation .....	07
Assembling .....	08
Electrical connection .....	10
Commissioning   Parameterisation   Maintenance .....	12
Repair .....	13
Returns   Disposal .....	15
EU-Declaration of Conformity .....	16

- Please, read and obey these safety instructions and the complete operating manual.

## 1. Safety instructions

- 1.1 The installation, initial operation and maintenance must be done by a qualified expert with electrical know-how.
- 1.2 Check before installation whether the measuring device is in compliance with the specification of the point of measurement like process and ambient temperature as well as the measuring range and whether the sensing weight is suitable for the bulk solids.
- 1.3 For the electrical connection take notice of the local and statutory rules and regulations and/or the VDE 0100.
- 1.4 Consider the data of the name plate on the device.
- 1.5 A fuse (with max. 6 A) has to be connected in series to the voltage supply.
- 1.6 Protect the signal contacts from voltage peaks when inductive loads are connected.
- 1.6 Check the cable entry, cable gland and clamping nut, to see if they are sitting correctly and are sealed.
- 1.7 Put the device into operation only when the unit is closed and the cover sealing is intact.
- 1.8 The sensing weight must not sink into the bulk good surface and must not slip away at the angle of repose or removal funnel.
- 1.9  Switch off the power supply, before opening the device (touch dangerous voltage).
- 1.10 Changes and repairs of the device are allowed only in so far as it is permitted in the operating instructions.

-  Prior to the use of the device in potentially explosive atmospheres please, read and obey the

## Special conditions and guidance for safe use

in the attached

## Explosions protection information

and note the operation instruction.

### 2. Use of the device

#### 2.1 Intended use

- The device is used for cyclical level measurement of bulk solids with a density of  $>0.02 \text{ t/m}^3$  in bunkers or silos.

#### 2.2 Normal operation

- Please operate the measuring device only according the intended use.
- Use the measuring device only within the specified temperature ranges for process and ambience.
- Protect the electronics compartment against pollution.
- In case the measuring device becomes damaged, please stop operation immediately.

#### 2.3 Improper use

- Ignoring safety regulations and operation instruction.
- Operation of the measuring device in inappropriate use.
- Installation of spare parts that are no original parts.
- Removal, addition or modification of components as far as it is not described in the documentation of the manufacturer.
- Violation of applicable standards and laws.

### 3. Data of manufacturer

Manufacturer	<b>MOLLET Füllstandtechnik GmbH</b>
Address	Industriepark RIO 103 74706 Osterburken Germany
Name of part	<b>MOLOSbob YO-YO sensing level measurement</b>
Typ	LF20- ...

### 4. Incoming goods inspection and storage

#### 4.1 Incoming goods inspection

- Please check whether packaging or content are damaged.
- Please check whether the supplied goods are incomplete or do not comply the requirements as set out in your order.

#### 4.2 Storage

- For storage and transportation the measuring device has to be packed shock-resistant.
- **Temperature range for storage** -40 °C ... +60 °C

### 5. Identification

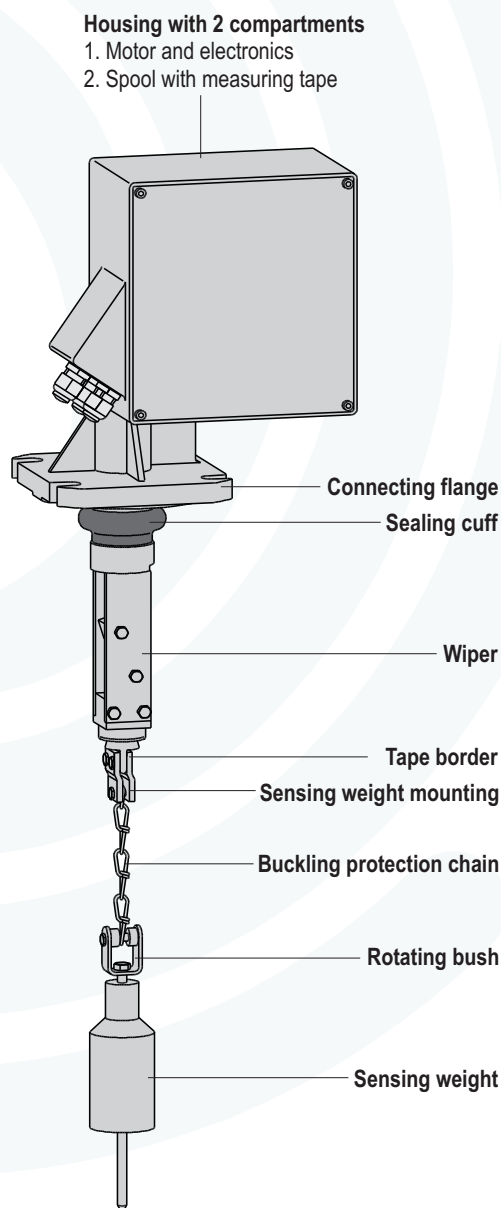

#### Certifications, certificates, approvals

- A Standard** = CE conform and IP67
- B ATEX** II 1/2D Ex ta/tb IIC T99°C **Dust**
- Y** Further approvals

#### Housing

- 8 Standard** Aluminium coated RAL 7001, lid Aluminium nature
- 0** Special coating

#### Measurement range

- 4 Standard** 15 m tape, stainless steel 1.4310
- 5** 32 m tape, stainless steel 1.4310
- 8** 42 m tape, stainless steel 1.4310

#### Wiper, maximum nozzle height

- A Standard** - wiper 230 mm Aluminium / steel
- B** Wiper 230 mm stainless steel 1.4301
- C** Wiper 500 mm Aluminium / steel
- D** Wiper 500 mm stainless steel 1.4301
- E** Wiper 1000 mm Aluminium / steel
- F** Wiper 1000 mm stainless steel 1.4301

#### Supply voltage

- 1 Standard** 90 V AC ... 253 V AC, 50/60 Hz
- 3** 20 V DC ... 28 V DC

#### Output

- A Standard** 0/4 ... 20 mA adjustable and 2 relay outputs
- C** 0/4 ... 20 mA adjustable and 4 relay outputs
- Y** Special version

#### Ambient temperature

- D Standard** -20°C ... +60°C
- E** -40°C ... +60°C with heating (ATEX II 1/2D -35 °C)
- F** -20°C ... +60°C with extended climate resistance <sup>1)</sup>
- Y** Special version

#### Process temperature

- 1 Standard** = -20°C ... +60°C
- 2** -20°C ... +150°C <sup>1)</sup>
- 9** Special version

#### Sensing weights

- A w/o sensing weight**
- B** Normal weight, steel
- C** Normal weight, stainless steel 1.4571
- D** Umbrella / steel weight
- E** Umbrella / stainless steel weight 1.4571
- G** Medium bag, Polyester
- N** Plastics weight, PVC and steel <sup>1)</sup>
- X** Float gauge, stainless steel 1.4571

#### Additional equipment

- 1 Standard** (no additional equipment)
- 2** Window and start push button <sup>1)</sup>
- 9** Special version

<sup>1)</sup> not available for use in potentially explosive atmospheres

LF20- [ ] [ ] [ ] [ ] [ ] [ ] [ ] [ ] [ ] [ ] ← **Order code**

1 2 3 4 5 6 7 8 9 10

## 6. Data of measuring device

### 6.1 Technical data

<b>Materials</b>	Housing	Aluminum die casting, coated RAL 7001
	Housing lid	Aluminum AlMgSi1
Process connection	Aluminum die casting	
	Tape	Stainless steel 301, modified
Wiper or	Aluminum/Steel	
	Stainless steel 304	
Sensing weights		
Normal weight 9.B	Steel	
Normal weight 9.C	Stainless steel 316Ti	
Umbrella 9.D	Polyester and steel	
Umbrella 9.E	Polyester and stainless steel 316Ti	
Medium bag 9.G	Polyester and stainless steel 316Ti	
Plastics weight 9.N	Plastics and steel <sup>1)</sup>	
<b>Weight</b>	w/o sensing weight	10 kg
	with sensing weight	11.5 kg

**Dimensions** 300 x 260 x 225 (HxBxD)

**Angle of inclination** max. 2°

**Protection type** **IP** IP67

**Maintenance** approx. after 45,000 measuring cycles

<sup>1)</sup> not available for use in potentially explosive atmospheres

### 6.2 Application data

<b>Ambient temperature</b>	7.D	-20 °C ... +60 °C (Standard)	<b>T<sub>amb</sub></b>
	with heater 7.E	-40 °C ... +60 °C <sup>1)</sup>	
	ATEX-device with heater 7.E	-35 °C ... +60 °C	
<b>Process temperature</b>	8.1	-20 °C ... +70 °C (Standard)	<b>T<sub>(Process)</sub></b>
	8.2	-20 °C ... +150 °C <sup>1)</sup>	
	with heater 7.E	-40 °C ... +70 °C <sup>1)</sup>	
	ATEX-device with heater 7.E	-35 °C ... +70 °C	
	Process pressure	-0.5 bar ... 1 bar	

<sup>1)</sup> not available for use in potentially explosive atmospheres

### 6.3 Technical measuring data

<b>Tape length</b>	3.4	15 m
	3.5	32 m
	3.8	42 m
<b>Tensile force</b>	max. 150 N	
<b>Tape run-off speed</b>	0.16 ... 0.25 m/s	
<b>Measuring accuracy</b>	± 2.5 cm or ± 1 Impuls (independent of selected measuring distance)	
<b>Highest measurable point</b>	Calculated from the block distance plus a minimum run-out length of 20 cm	

► The individual value of the block distance is preset when delivered and has only to be adjusted when the sensing weights are replaced.

### 6.4 Electrical data

<b>Supply voltage</b>	5.1	90 ... 253 V (AC) 50-60 Hz	<b>Supply</b> 
	or 5.3	20 ... 28 V (DC)	
<b>Power consumption</b>		<b>AC</b> = 150 VA	<b>DC</b> = 150 W
	with heater 7.E	<b>AC</b> = 170 VA	<b>DC</b> = 170 W
<b>Terminals</b>	max. 2.5 mm <sup>2</sup>		
<b>Cable entry</b>	3x screwing M20x1.5 (6 ... 13 mm)		

<b>Signal inputs</b>		2 available for external start or lock measurement
	<b>active</b>	Input voltage range of an external control 12 ... 24 V DC
	<b>passive</b>	Connection of an external command unit, e.g. switch, key, relay contact (Start pulse length: min. 200 ms)

<b>Signal outputs</b>		<b>active</b> 0/4 ... 20 mA current output, working resistance max. 600 Ω
-----------------------	---	---

<b>Relay outputs</b>	optional 6.C	2 relay outputs (Standard) 2 additional relay outputs
----------------------	--------------	--

#### Selectable relay functions

**Counting pulse** Pulses according tape length rolled out

**Reset pulse** Pulse before every new measurement e.g. to reset an external counter

**Gating of counting pulse** Pulse during running up the sensing weight, e.g. to hide counting pulses

**Measurement active** Pulse during active measuring cycle, e.g. to lock a filling device in order to protect the sensing weight from being covered by medium

**End of measurement** Pulse when sensing weight reached upper end position

**Alarm** Output of fault states

**Service interval** Information on required maintenance

<b>Contact load</b>		250 VAC, 6 A Silver-cadmium-oxid contacts, gold plated
---------------------	---	---

<b>Optocoupler output</b>		for counting pulse (optional when 4 relay are selected)
---------------------------	---	---

**Loading capacity** U max. 30 V DC, I max. 10 mA

**Break down information** recallable via following interfaces

**Local display** Error symbol  
Error code with plain text display

**Current output** State programmable:

#### Minimum

Current value ≤ 3.6 mA (4 - 20 mA) or  
Current value 0 mA (0 - 20 mA)

#### Maximum

max. current value +10% (=22 mA)

**Relay output** Alarm function

6.5 Dimensions

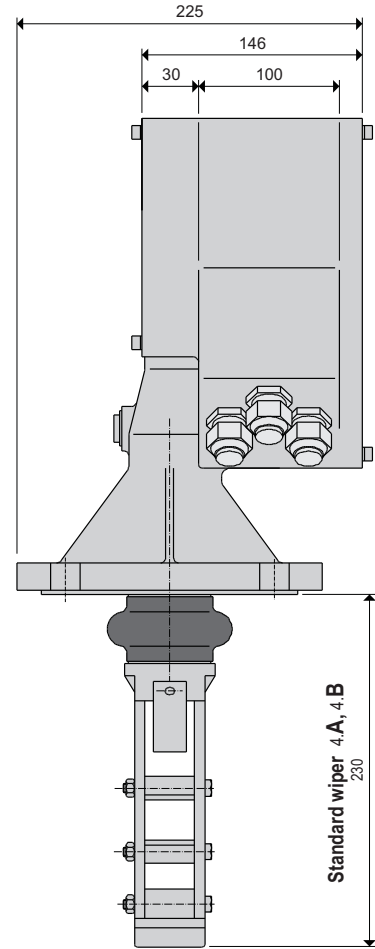
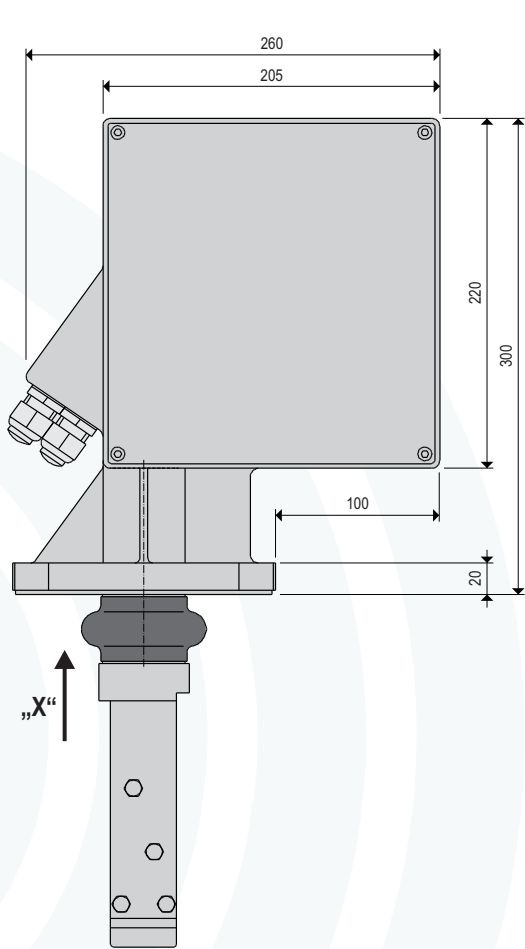

6.6 Process connection flange view „X“

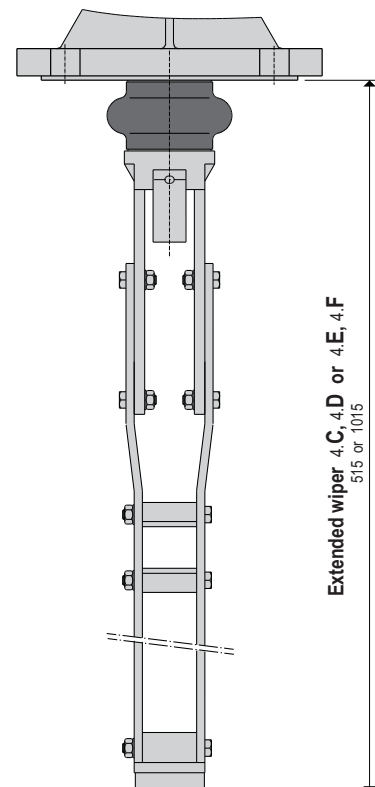
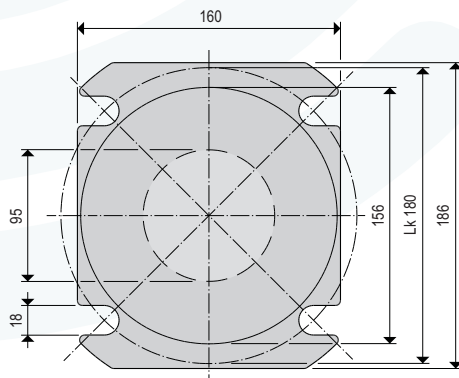

6.7 Sensing weights

► !!! Select a sensing weight that will not sink into the bulk good surface and will not slip away at the angle of repose or removal funnel.

**Normal weight, order code 5.B/5.C**

Steel/stainless steel for temperatures up to +150 °C

For granulates and compacted bulk solids.

**Bulk density** >0.3 t/m<sup>3</sup>

**Angle of repose** steep with spike  
flat w/o spike

The spike avoids slipping or tilting of the sensing weight on a steep bulk surface.

Spike (screw-off)

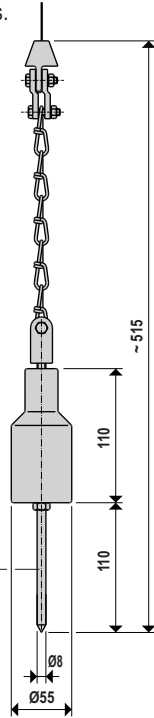

022-0207

**Bag weight, order code 5.G**

Polyester and stainless steel for temperatures up to +150 °C

For granulates and compacted bulk solids.

**Bulk density** >0.2 t/m<sup>3</sup>

**Angle of repose** flat

Avoids damage of outlet devices.

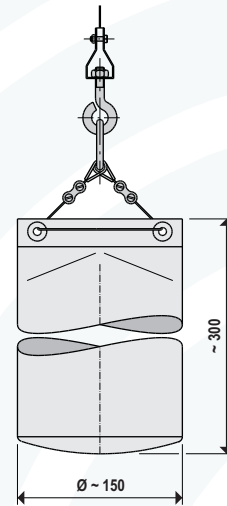

022-0208

The bag is filled with the respective medium stored in the bunker or silo.

**Plastic weight, order code 5.N**

PVC and steel for temperatures up to +70 °C

For granulates and compacted bulk solids.

**Bulk density** >0.3 t/m<sup>3</sup>

**Angle of repose** flat

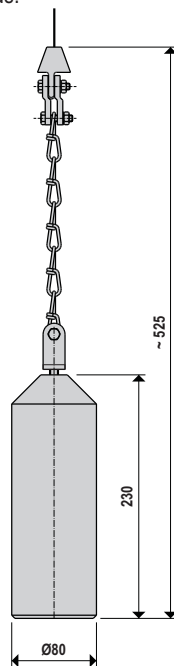

022-0209

**Umbrella weight, order code 5.D/5.E**

Steel/stainless steel and Polyester for temperatures up to +150 °C

For very light and loose bulk solids.

**Bulk density** >0.02 t/m<sup>3</sup>

**Angle of repose** steep with spike  
flat w/o spike

A large square surface prevents it from deeply sinking into the bulk solid.

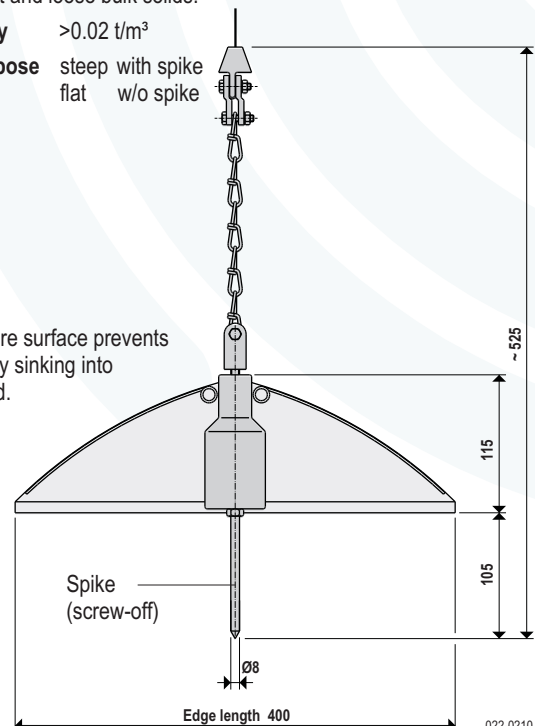

022-0210

► Not available for use in potentially explosive atmospheres.

## 7. Installation

### 7.1 Place of installation - Slope

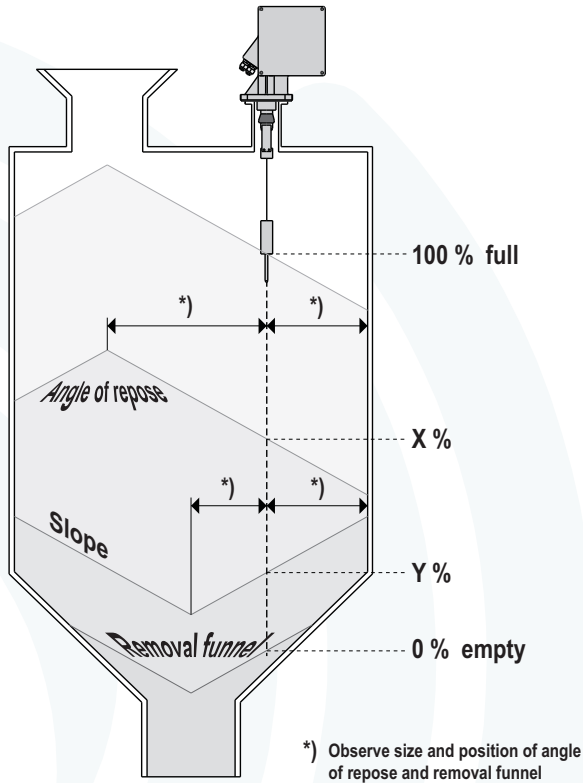

022-0202

### 7.2 Place of installation - distances and nozzle

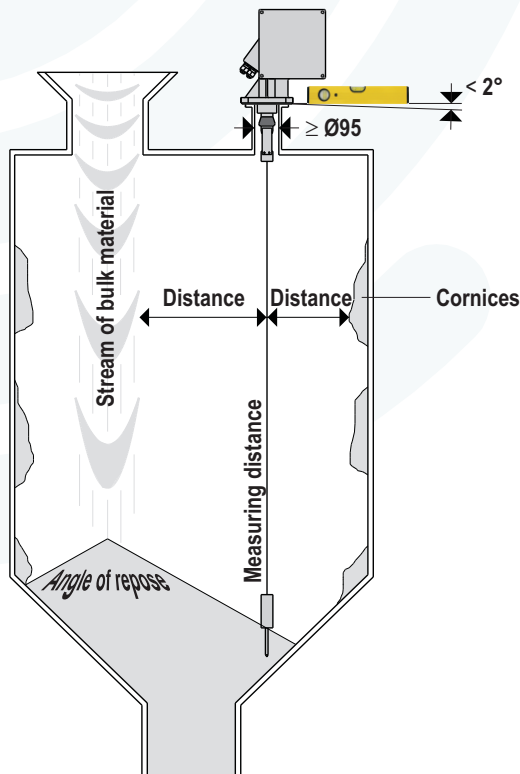

022-0218

### 7.3 Planing of place of installation

- Observe size and position of angle of repose and removal funnel. Select a measuring point that is approximately in the middle of the slope.
- Keep enough distance between measuring tape and internal fixtures and fittings in order to avoid contact when the sensing weight is oscillating.
- Select the mounting position on the bunker or silo roof in such a way that falling bulk goods during filling or collapsing cornices cannot spill the sensing weight and cannot damage the measuring tape.

### 7.4 Installation nozzle

- The device is best mounted on a nozzle with a horizontal (<math>< 2^\circ</math>) counter flange DN100 PN16 (dimensions acc. to EN 1092-1) or a flange with the same connection conditions.
- The minimum internal diameter of the nozzle has to be 95 mm.
- The length of the nozzle comply with the length of the wiper. e.g. Wiper 230 mm  $\geq$  nozzle length 230 mm.
- Sensing weight has to be outside of the nozzle in the uppermost position when measuring tape is completely wound up.

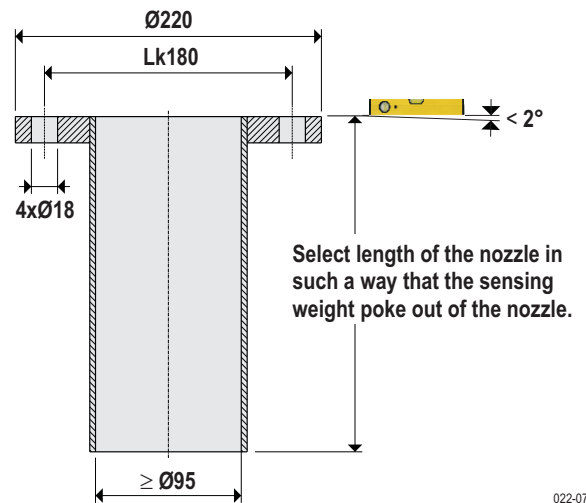

022-0701

### 7.5 Installation nozzle for +150 °C

- For the process temperature range -20 ... +150 °C (option 8.2) wiper and nozzle have to be at least 500 mm long.

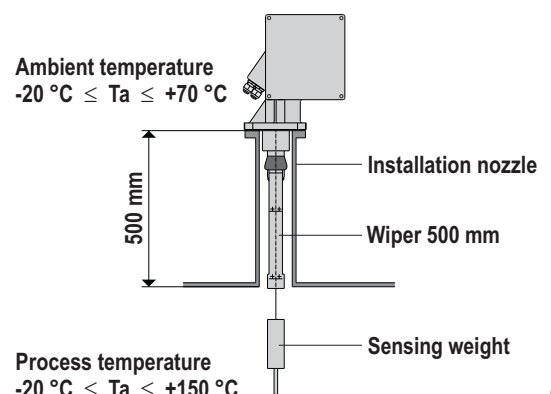

022-0702

## 8. Assembling

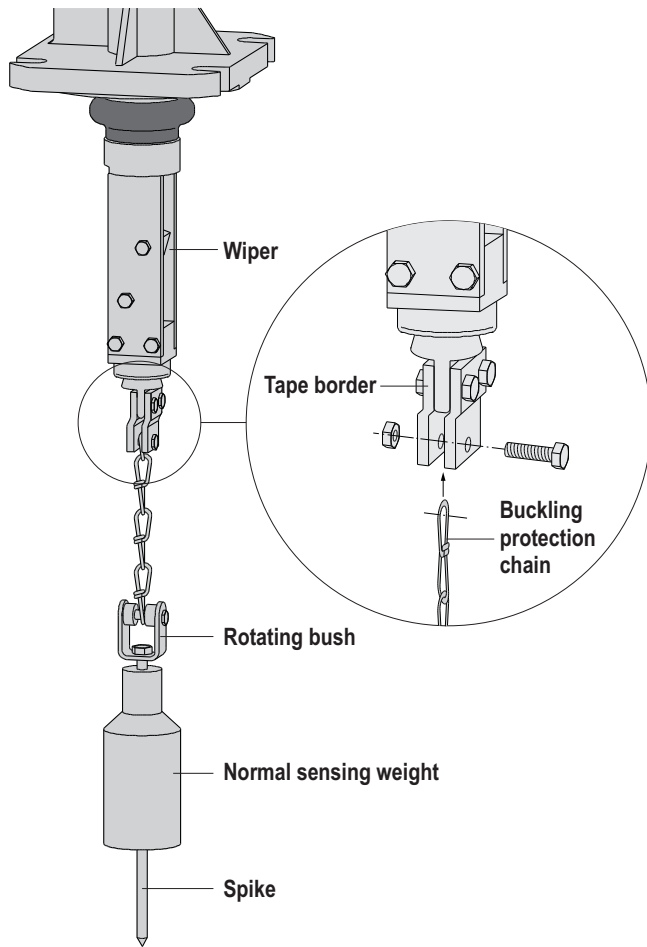

### 8.1 Assembling sensing weight

- Sensing weight is delivered preassembled including rotating bush and buckling protection chain.
- Fix the sensing weight on-site at the tape border with the screws provided.

### 8.2 Assembling LF20

- First put a sealing ring on top of the flange.
- Insert the sensing weight carefully through the nozzle into the silo or bunker.
- Put now the measuring device on top of the flange.
- Observe the position of the cable entry for the electrical connection.
- Assemble the device horizontal and fix it with four suitable screws M16, plain washers and nuts.

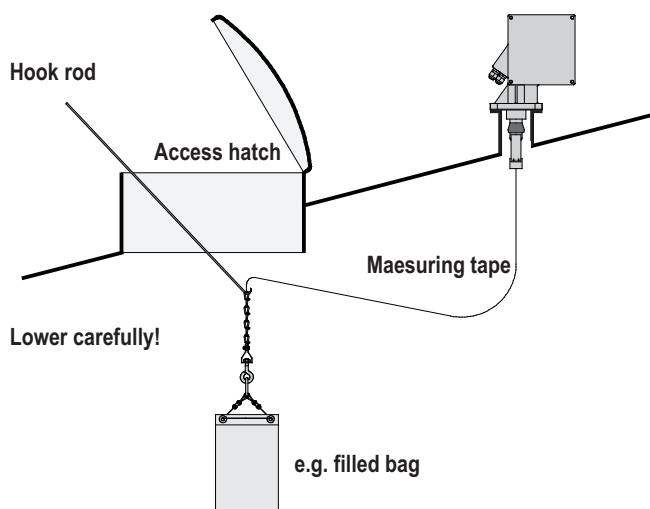

### 8.3 Insert large sensing weights

- Normal weights, plastic weights and umbrella weights can be insert into the silo or bunker through the installation nozzle.
- When using larger sensing weights, such as a filled medium bag for example, a point must be present in the design of the bunker or silo (e.g. access hatch) where these weights can be installed.



## 8. Assembling

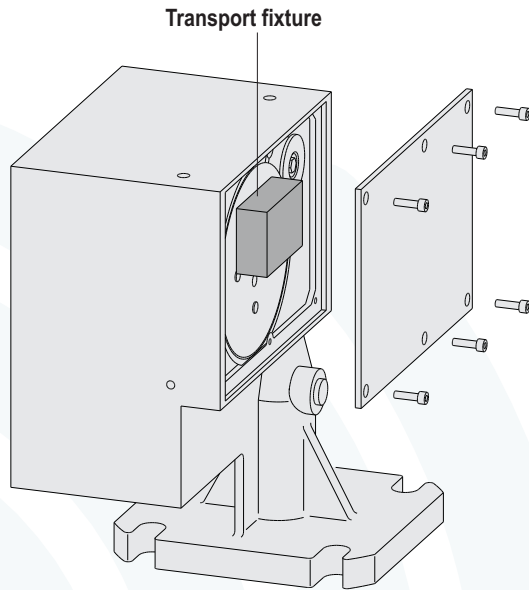

### 8.4 Transport fixture

- Please remove the transport fixture in the tape spool compartment as soon as the measuring device is fixed on top of the flange (see figure)!
- Unpredictable device reactions will occur, if this transport fixture is not removed.
- Check the correct position of the cover sealing before you close the cover.

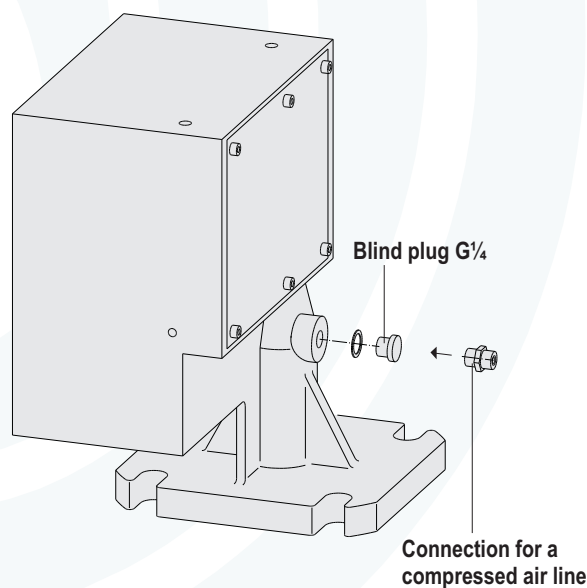

### 8.5 Protection against dust

- In case of severe dust emission in bunkers or silos a compressed air line can be connected above the mounting flange in order to generate a slight over pressure.
- A G $\frac{1}{4}$  bore is provided for this purpose.
- Air volume as required.

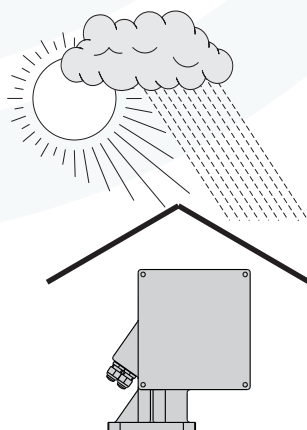

### 8.6 Check after assembling

- Are there any damages at the measuring device (visual check)?
- Is the transport fixture in the tape spool compartment removed?
- Are the number of the measuring point and the labelling correct?
- Is there enough protection against direct sunlight and heavy rain?

### 8.7 Weather protection

- Protect the measuring device against direct sunlight and heavy rain by using a weather protection cover or fit the protective hood available as an accessory.

## 9. Electrical connection

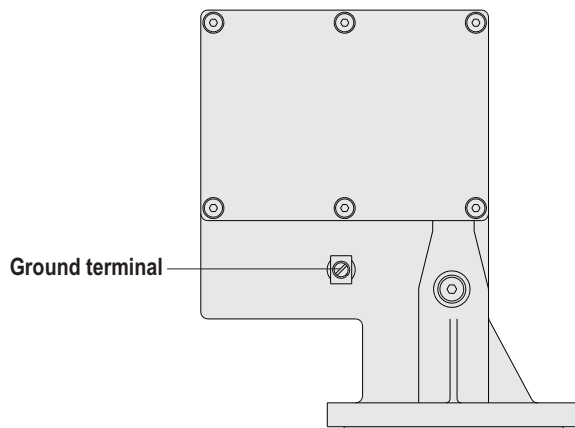

### 9.1 Potential equalization

- Connect the ground terminal on the housing to the local potential equalization.
- Wire cross-section  $\geq 2.5 \text{ mm}^2$ .
- Use wire as short as possible.

### 9.2 Potentially explosive dust atmospheres

- Use devices with a valid  $\text{Ex}$ -marking only.
- For use of the device in potentially explosive atmospheres the applicable national rules and standards have to be obeyed. Always observe the explosion protection information and the included safety instructions.

### 9.3 Check before electrical connection

- The voltage supply must match the voltage specified on the name plate.
- Switch off the voltage supply before connecting the device.

### 9.4 Position of terminals

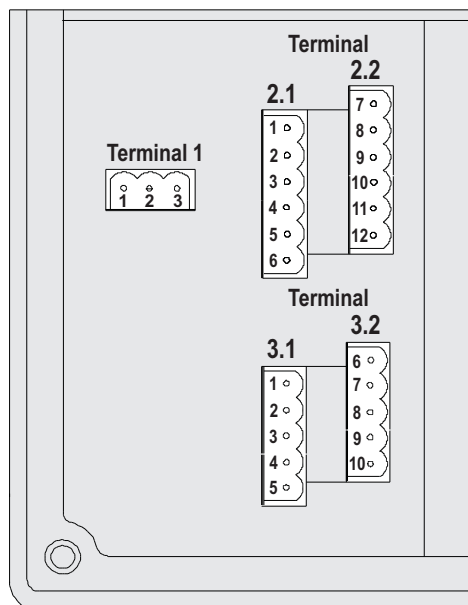

### 9.5 Electrical connection

- For connection a basic installation cable is sufficient.
- Maximum wire cross-section for the terminals  $\leq 2.5 \text{ mm}^2$ .
- To protect electrical circuits use electrical fuse with maximal 6 A.

**9. Electrical connection**

For connection a basic installation cable is sufficient.

**Supply voltage**  **AC**

Circuit diagram - Terminal 1

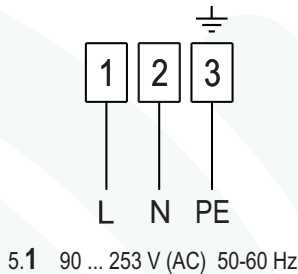

**Supply voltage**  **DC**

Circuit diagram - Terminal 1

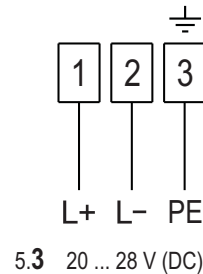

**Relay output** 

Circuit diagram - Terminal 2.1

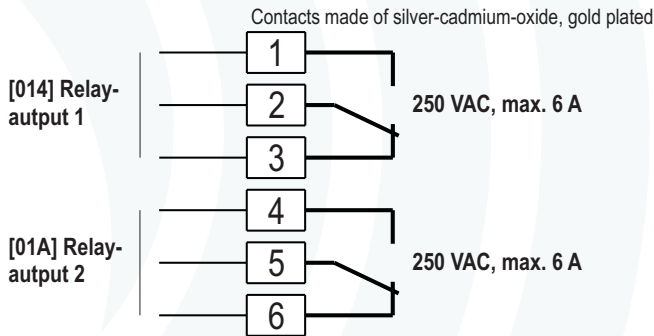

**Relay output**  **optional 6.C**

Circuit diagram - Terminal 2.2

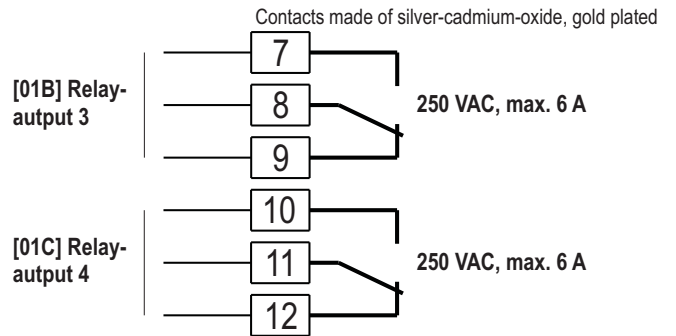

The rest position matches with the position of the relays without power supply.  
This represents the alert condition in case the function "alarm" is selected.

**Signal inputs**  **active** Pulse length  $\geq 200$  ms

Circuit diagram - Terminal 3.1 and 3.2

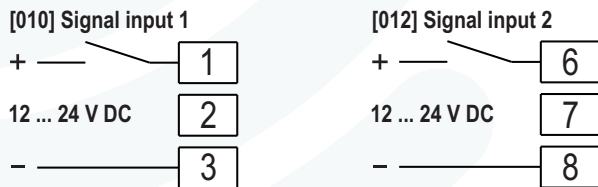

**Signal inputs**  **passive** Pulse length  $\geq 200$  ms

Circuit diagram - Terminal 3.1 and 3.2

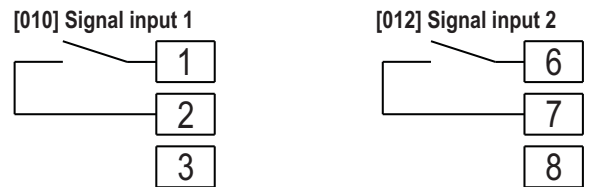

The **signal inputs active** or **passive** can only be used alternatively.  
A double connection from active and passive can not be used!

**Current output** 

Circuit diagram - Terminal 3.2

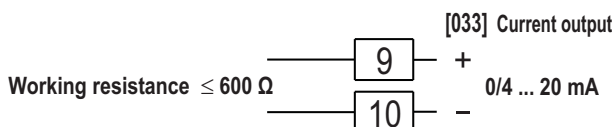

**Optocoupler output**  **optional 6.C**

Circuit diagram - Terminal 3.1

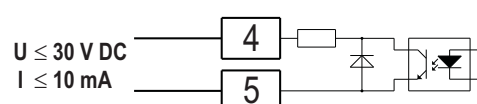

001-0203

## 10. Commissioning

### 10.1 Checks before commissioning

- Check whether the terminal assignment is correct.
- Check the tightness of the cable gland.
- Switch on the supply voltage.
- The measuring device will be operable, if the LCD-display is shining.

## 11. Parameterisation

### 11.1 Parameterisation

- Please undertake the parameterisation of the measuring device by using the instruction for parameterisation.
- Close the housing with the cover after the parameterisation has been finished.

## 12. Maintenance

### Wiper

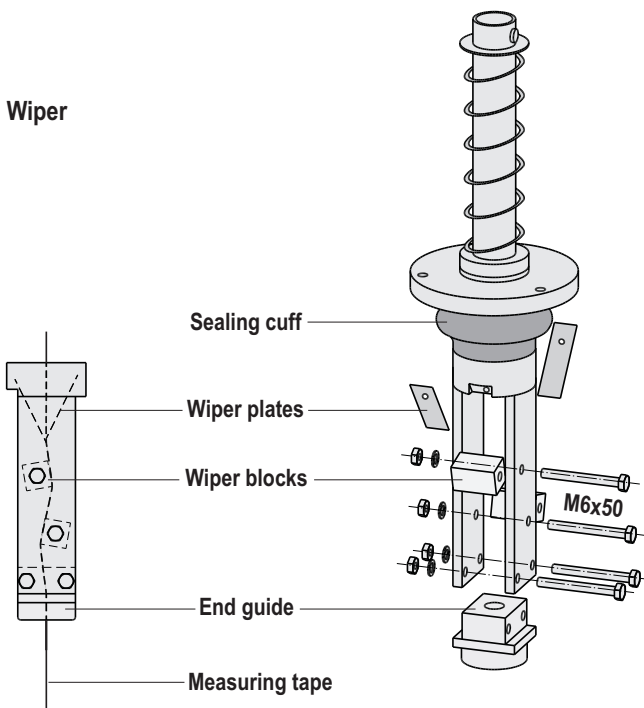

### 12.1 External cleaning

- Ensure that the cleaning agent used for externally cleaning does not attack the housing surface and seals.

### 12.2 Cleaning tape spool compartment

- The cleaning periods depend on the properties of the bulk solid.
- In case of severe dust emission it is recommended to connect a compressed air line above the mounting flange in order to generate a slight over pressure (see chapter 8.5 Assembling).

### 12.3 Wiper check

To check the wiper you have to remove the LF20. To do so, please note chapter 8 Assembling.

- Check whether the edges of the wiper blocks are still sharp (round edges do no more clean the measuring tape correctly).
- If necessary please turn or substitute the wiper blocks.
- Check the end guide for cuts caused by the measuring tape. If there are deep cuts, there will be a risk of measuring tape jamming.
- If necessary please substitute the end guide.
- In case of abrasion please substitute the wiper plates.
- Check whether both wiper plates are securely in contact with the measuring tape.
- Check whether the bellows are still in perfect condition and replace in case of damages.

### Tape border

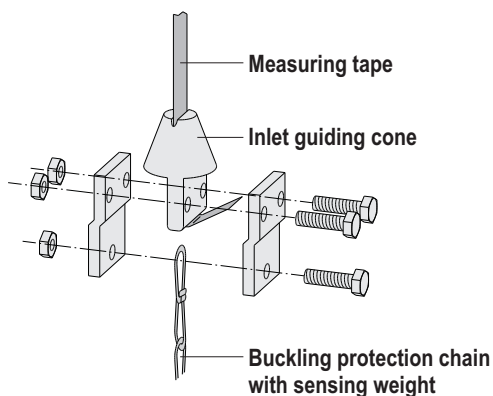

### 12.4 Check of the measuring tape

- Check the measuring tape in regular intervals.
- If the visible part of the measuring tape is damaged, uncoil a section by operation manual [020] until it looks perfect.
- Cut off the damaged parts and re-mount the sensing weight.

► **Do not cut off too much. Note the original length and the measurement range required (silo height).**

- If the measuring tape is damaged on a longer part, please replace the entire measuring tape.

### 12.5 Check of tape spool compartment

- Check the tape spool compartment in regular intervals.
- If the tape spool is damaged, please replace it.
- If the counting wheel is very sluggish to turn in spite of removed tension of the measuring tape or in case it is damaged, please replace it.
- Please replace deteriorated or damaged cover seals.

► **Please refer to chapter 13 repair for details to dismantle the LF20.**

## 13. Repair

### 13.1 Repair of Ex-certified devices

▶ **!!! Ex-certified devices may only be repaired by MOLLET-service team.**

### 13.2 Replacement of components

- Only original spare parts from MOLLET must be used.
- When ordering spare parts, please note the device designation on the nameplate.
- Parts may only be replaced with the same parts.

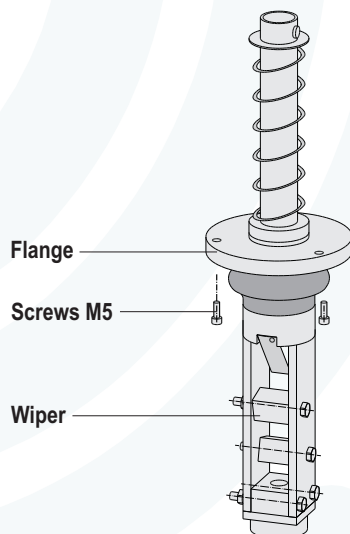
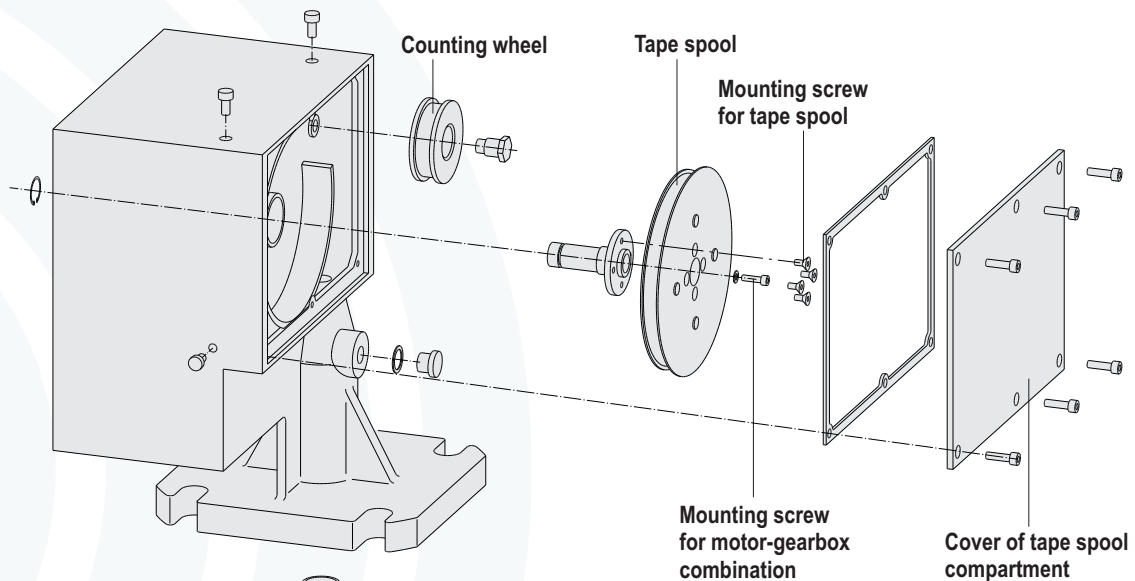

### Tape border

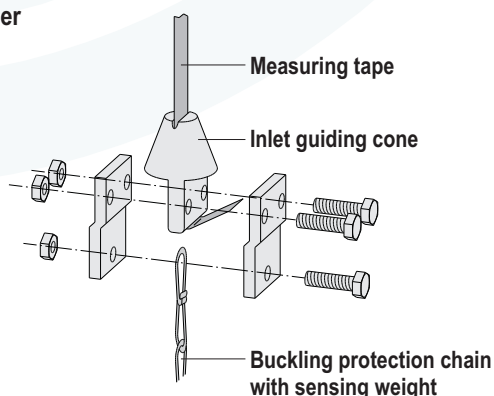

### 13.3 Change of measuring tape

1. Move down the sensing weight at least 5 cm by using the **manual mode [020]** in order to remove tension of the measuring tape.
- ▶ **When using larger special sensing weights, the weight must be lowered to an appropriate hatch (see 8.3 assembling).**
2. Switch off and disconnect the supply voltage of the device.
3. Remove and/or expose the LF20 until the wiper and the sensing weight are accessible. .
4. Remove the sensing weight including the tape border from the measuring tape.
5. Unscrew the four screws on the tape spool.
6. Removed carefully the tape spool and the unwound part of the measuring tape from the device.
7. A new tape spool is then installed in reverse order.

### 13.4 Change of wiper

1. The wiper can be replaced as soon as the device is prepared as described in chapter 13.3 change of measuring tape.
2. Unscrew the three M5 screws at the flange of the wiper.
3. After that you will be able to take out the wiper.
- ▶ **Take care that during mounting and dismounting the measuring tape is positioned correctly in the wiper. The tape must not be turned in tape spool compartment. In order to check this open the cover of the tape spool compartment.**
4. Mounting and dismounting in reverse order.

13. Repair

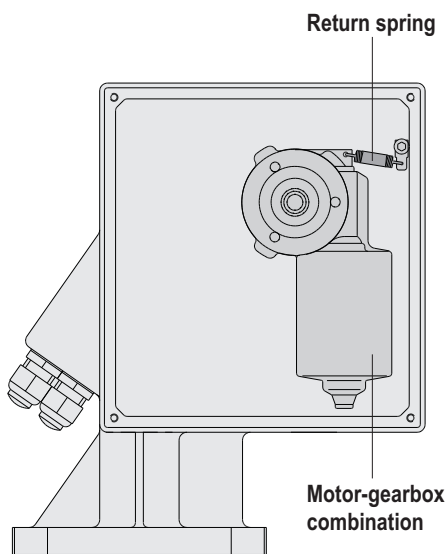
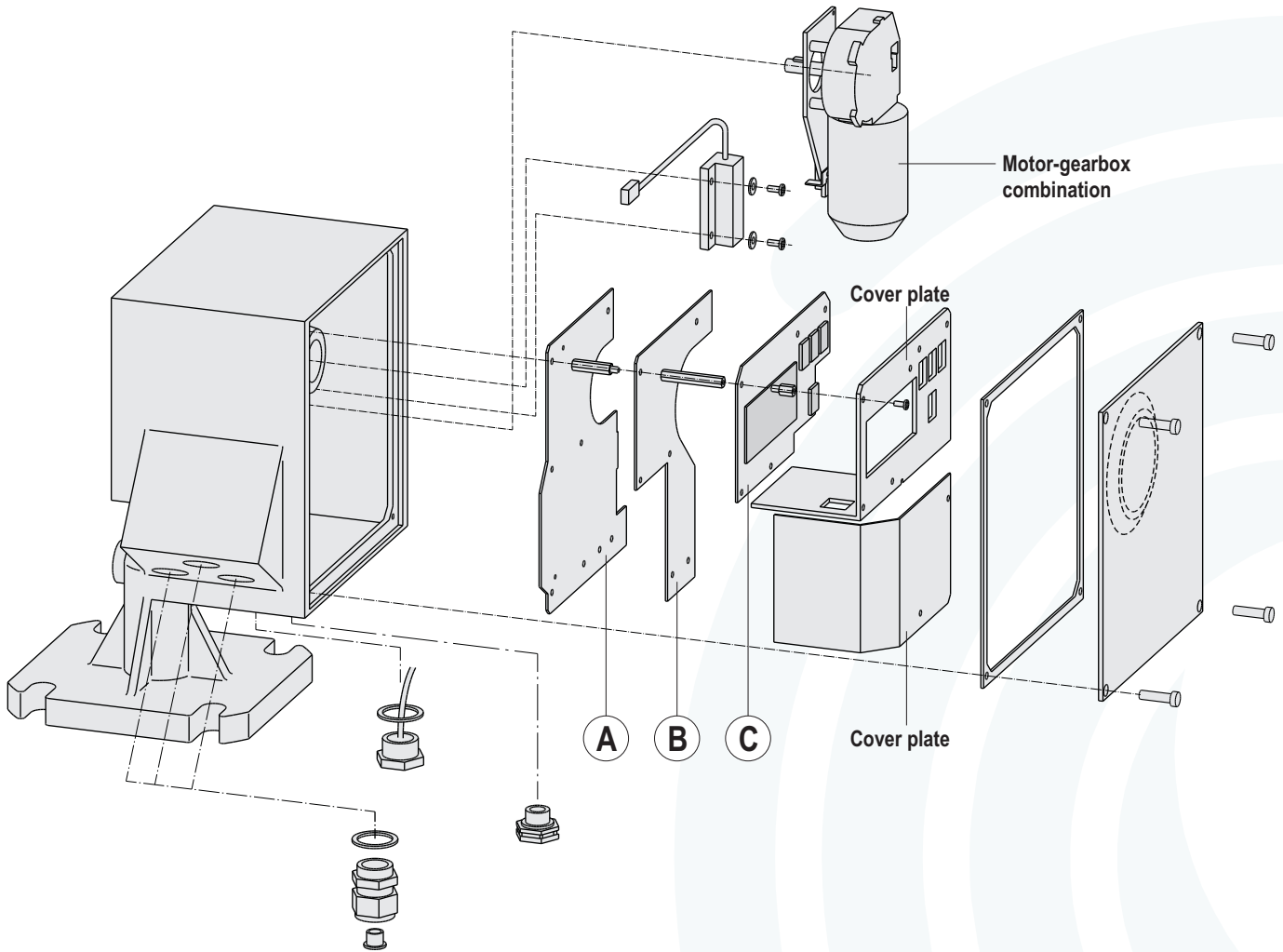

13.5 Change of drive unit

1. Move down the sensing weight a little bit by using the **manual mode [020]** in order to remove tension of the measuring tape and the drive shaft.
2. Fasten the sensing weight or measuring tape.
3. Switch off and disconnect the supply voltage of the device.
4. Unscrew mounting screws of the cover plates and remove them.
5. Disconnect the plug for the motor connector cable at the top right of the motor-gearbox combination.
6. Unscrew mounting screw of the motor-gearbox combination on the side of tape spool compartment (see figure page LF-BA-13).
7. Carefully remove the top PCB **C** (processor + display), you can pull out the PCB for approx. 3-4 cm and put it on top of the housing. (PCB is still connected to 2 flat cables)
8. Carefully hang out the return spring. The motor gearbox combination can now carefully be removed .
9. A new motor-gearbox combination has to be installed in reverse order.

▶ **!!! Mounting screw of the motor-gearbox combination has to be installed with a copper washer (ATEX).**

## 13. Repair

### 13.6 Change of electronic and PCBs

- Note all parameters into the parameterisation instruction before replacing the electronic or single PCBs.
- After the replacement of the electronic or single PCBs a basic setup has to be done and all parameters have to be re-inserted.
- The PCBs should only be replaced by a specialist.
- A precise description of the replacement process will be delivered with every new piece of PCB, therefore such a description is not provided at this point.
- When working with electronic components ensure that you have sufficient ESD protection (protection against electrostatic discharge).
- Only use the PCBs permitted for the device type when replacing parts.
- The use of incorrect electronic parts may damage the device and the Ex-certification will be lost.

## 14. Returns to the manufacturer

- Remove all residue of the bulk goods before returning the device to the manufacturer.
- Pay particular attention to seal grooves and scoring in which residue of the bulk goods may stick.

► **That is of particular importance if the bulk goods poses a risk to health, e.g. flammable, poisonous, corrosive or carcinogenic.**

- Please although specify:
  - The chemical and physical characteristics of the bulk goods
  - Description of the application
  - Description of the error that has occurred (when indicated, specify the error code)
  - Operating period of the device

## 15. Disposal

- The level measurement device can be recycled.
- Disposal of the level measurement device is subject to the environmental legislation of the respective country in effect for the operator's premises and production conditions.

## EU-Konformitätserklärung EU-Declaration of Conformity

Wir/We

**MOLLET Füllstandtechnik GmbH**

Industriepark RIO 103  
D-74706 Osterburken  
Tel. 06291 64400 Fax 06291 9846

erklären in alleiniger Verantwortung, dass das Produkt:  
declares under our sole responsibility, that the product:

### Füllstand-Messgerät / Level indicator

Lot-Füllstandmessung / YoYo sensing level measurement

Typ/Type **LF20 ...**

den folgenden Europäischen Richtlinien entspricht:  
conforms with the following European directives:

**EMV-Richtlinie**

**EMC directive**

**2014/30/EU**

**Niederspannungsrichtlinie**



**Low voltage directive**

**2014/35/EU**

Angewandte harmonisierte Normen oder normative Dokumente:  
Applied harmonized standards or normative documents:

**EN 61326-1:2013**  
**EN 61010-1:2010**

**EN 61326-2-3:2013**  
**EN 60529:1991 + A1:2000 + A2:2013**

Und die Geräte mit  - Kennzeichnung entsprechen zusätzlich der folgenden Europäischen Richtlinie:  
And the devices with  - marking conform additional with the following European directive:

**ATEX-Richtlinie**

**ATEX directive**

**2014/34/EU**

Angewandte harmonisierte Normen oder normative Dokumente:  
Applied harmonized standards or normative documents:

**EN 60079-0:2012 + A11:2013**

**EN 60079-31:2014**

EG-Baumusterprüfbescheinigungsnummer:  
EU-Type Examination Certificate:

**BVS 14 ATEX E 120**

Ausgestellt von:.  
Issued by:

DEKRAEXAM GmbH, Bochum (0158)

Qualitätssicherung:  
Quality assurance:

TÜV NORD CERT GmbH, 30159 Hannover (0044)

Osterburken, den 10.05.2016



Wolfgang Hageleit  
Geschäftsführer / managing director

Diese Erklärung darf nur unverändert weiterverbreitet werden.  
This declaration is only allowed to hand out in unchanged form.